

This new 15" LCD video monitor is designed to be a form, fit and near functional replacement for the popular MGG 15" EQ/2 HR CRT monitor



Features and Benefits

- Drop in replacement for MGG15 EQ/2 HR
- Composite input only via BNC connector
- Optional Analog RGB only version via 15pin "D"
- Wide viewing angles
- High speed response
- Low Power consumption
- High brightness and contrast on XGA panel

Specifications

Model Name	LCD 15" MGG
Viewable Size Image	15" (378mm)
Active Display Area(mm)	303(H) x 227(V)
Pixel Pitch(mm)	0.264(H) x 0.264(V)
Number of Pixels	1024 x 768 (XGA)
Contrast Ratio	450:1(typ.)
Display Color	262,144 (6bit/colors)
Brightness(CD/m ²)	300
Viewing Angle(CR>=10)	170 degrees H & V
Signal Connector	BNC or 15pin HD (VGA) optional
Power Source	AC100~240V, Universal, ± 10%
Power Consumption	32W typical, normal operation
Power Management	VESA DPMS Compliant
Speaker	None
Controls	Rear Mounted via OSD
Operating Conditions	0 - 45 degrees C Max 85% NC
Size & Weight	349.5mm(W) x 290mm(H) x 242mm(D) 6.3 KG

Outline Dimensions

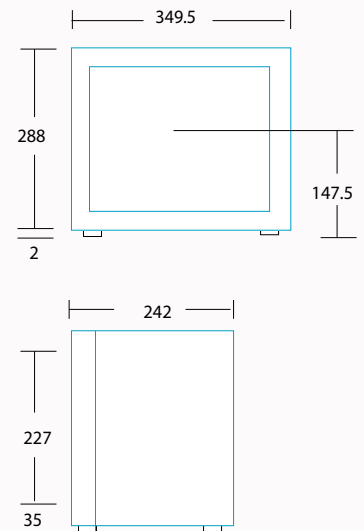

Measurements in mm

Hantarex International Limited
Unit 14 – Forest Hill Business Centre
Forest Hill
London SE23 3JF

For further details e-mail: sales@hantarex.com
 Tel: +44(0)20 8778 1414 Fax: +44(0)20 8659 9348

www.hantarex.com